



LAUNCH YOUR CAREER

IN SUSTAINABLE
SOLUTIONS WITH
SCM FRIGO

A **BEIJER REF** Company

JOIN US
FOR A MORE
SUSTAINABLE
FUTURE



Index

SCM Frigo, who We are	p. 4
Latest News	p. 6
Meet our HR Manager	p. 8
Care of People	p. 9
A Culture of Kindness and Empathy	p. 10
Daily Life at SCM Frigo	p. 11
Why SCM Frigo is the Right Place for You	p. 13
Join Us!	p. 14

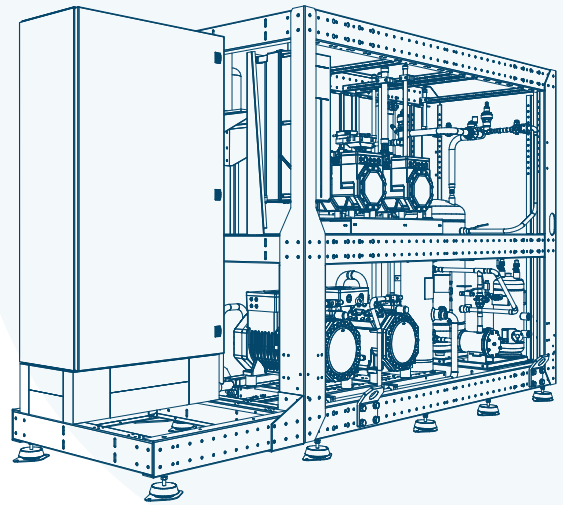

SCM Frigo S.p.A. is a **leading company in the industrial and commercial refrigeration sector**, with a strong focus on innovation and sustainability. **Founded in 1979**, SCM Frigo has developed a solid reputation thanks to the quality of its products and the ability to respond to the needs of an ever-evolving market.

We are leaders in the **design and production** of condensing units, boosters, and chillers in the refrigeration sector. Our shared passion, advanced technologies, and goal of **maximizing sustainability** with minimal environmental impact have led to the spread of **our CO₂ refrigeration systems worldwide**.

Who We are

SCM Frigo operates in the **refrigeration sector with cutting-edge technologies**, exporting our range of CO₂ products worldwide.

Commercial refrigeration

We design and manufacture one of the **most complete ranges of “commercial” refrigeration equipment**. Applications range from smaller systems for convenience stores to large systems for hypermarkets.

Industrial refrigeration

We design and manufacture one of the **most complete ranges of “industrial” refrigeration equipment and industrial chillers**. Our applications are designed for cold storage rooms for food preservation and distribution, as well as for ice rinks and processing plants.

Training

We offer specialized **training courses for all employees, technicians, and installers** from around the world who want to learn to manage CO₂ refrigeration systems in various configurations.

Customized solutions

We can provide **customized solutions to meet the specific needs** of each customer.

Strategic collaborations

SCM Frigo has been selected as one of the **strategic partners for Danfoss’s Smart Store project**, which serves as a functioning supermarket and development center to test new solutions.

AMONG THE BEST PERFORMERS 2024 OF THE PIOVESE REGION

On Friday, September 20th, the second event of "Imprese Best Performer 2024" took place, showcasing the 100 best performing companies of the Piovese area at the Teatro Filarmonico in Piove di Sacco (PD). Among these outstanding companies, SCM Frigo S.p.A. proudly stood out.



SCM FRIGO ENTERS THE U.S. MARKET



SCM Frigo S.p.A. attended the FMI Energy Fair in Baltimore, held from September 23 to 25, 2024. SCM Frigo is beginning to enter the U.S. market, complementing foreign markets, with its transcritical CO₂ system, which has been recognized with the ATMO Approved label by ATMOSphere.

CHILLVENTA 2024

Efficiency. Sustainability. Reliability.

For the first time, SCM Frigo S.p.A. and FENAGY have joined forces to create a cutting-edge heat pump, setting a new benchmark for high performance in the commercial and industrial sectors, with capacities ranging from 30 to 300 kW. This innovative solution maintains impressive temperatures of up to 85°C, even in the most challenging conditions.

We unveiled this new product at Chillventa 2024! From office buildings to industrial plants, this heat pump ensures efficient and reliable heating. Using CO₂ as a refrigerant, it is safe, non-toxic, and future-ready. When innovative minds come together, ideas ignite.

We are excited about this collaboration and what it means for the future of sustainable heating solutions!



Meet our HR Manager

Valentina Brondolin

"At SCM Frigo SpA, we firmly believe that the future is in the hands of those who dare to dream and work with passion."

Motivation, Respect, Innovation and **Sustainability** are core values in SCM Frigo and our focus is to pursue them every single day."

Nice to meet you

Valentina Brondolin



SCM FRIGO COLLABORATE WITH PADOVA UNIVERSITY



UNIVERSITÀ
DEGLI STUDI
DI PADOVA

SCM Frigo is the right place to start a new journey after graduation. A dynamic environment that can inspire, full of knowledge where everyone can bring new ideas. **A place in which you will continue to learn.**

OUR BLOG

CARE OF PEOPLE

At SCM Frigo, we believe that what truly sets us apart as a company is our unwavering commitment to people. From our employees and partners to our customers and communities, we understand that our success is deeply rooted in the relationships we build and nurture. That's why, at the heart of SCM Frigo, you'll find a culture that prioritizes caring for people above all else.

We have always emphasized the importance of listening to and learning from our team members, the creative minds, and dedicated professionals who bring their expertise to the table every day. To highlight their contributions, we created our "Care of People" series, a space where we share the journeys, challenges, and triumphs of our employees.

Here are some testimonials

A Culture of Kindness and Empathy



Kindness is always a strong word within SCM Frigo.

*“One of the most important aspects is that SCM Frigo cultivates empathy and continually builds trust. Before starting to work in this company, I thought that working in a large company necessarily meant being just a number, but I had to change my mind because it is evident that who you are matters a lot. On Monday mornings or even during meetings, the first questions I hear are about each other’s families and weekends. It’s not just your job title or your presence in that context but also who you are behind that role” - **Catalina***



Federica summarizes the organizational culture and its impact in one sentence: *“I think the most rewarding thing for me at SCM is the ability to be myself.”* She continues: *“With my weaknesses and strengths. The fact of being a woman, a woman engineer, here at SCM is valued and not something to be modified. It’s the place where I spend most of my time during the week, and for me, this must be a place where I am not afraid to make mistakes because I can be corrected and encouraged to do my best.”*

Daily Life at SCM Frigo and Career Growth

*“My journey with SCM Frigo started in 2017 as a Quotation Specialist, preparing offers for markets all over the world. After three years, I had the opportunity to take on a new challenge and became a Sales Engineer. This step completely changed my career, bringing me closer to customers and projects.” – describes **Thomas**.*

“As a Sales Engineer, I now follow the Benelux market, organize technical training, and attend exhibitions. I support customers from the first idea to the delivery of their units, ensuring quality and the right technical solutions. It is rewarding to be directly involved in every step and to see the results.”

“One of my most memorable moments was negotiating my first big project. It was exciting and risky, but thanks to determination and technical knowledge, I won the order. That experience gave me confidence and helped me grow into my role.”



“At SCM Frigo, I found a strong team willing to share knowledge and support growth. Every project is different and special. One of my favorites was a chocolate factory installation, where precision was key — and where our units became part of producing something everyone loves.”

“Looking ahead, I aim to expand my responsibilities to new markets. With training, daily challenges, and a supportive environment, SCM Frigo gives me the tools to keep growing. I hope my story shows new colleagues that with dedication, long-term growth here is possible.”



Valentina and **Maila**, together and respectively, thank SCM Frigo for “these wonderful opportunities that are allowing me to achieve my goals and grow as a person.”

“SCM has given me the chance to acquire new skills, constantly challenge myself, all in a work environment that makes you feel at home.”

To the feeling of being at home, Kevin adds that of being part of a bigger picture.

“Being part of a bigger picture, producing an excellent product, achieving significant results, and helping our customers.

All this makes me proud to be part of SCM Frigo.”

Why SCM Frigo is the Right Place for You

Technological Innovation

SCM Frigo is at the forefront of research and development of eco-friendly refrigeration solutions. We use advanced technologies to improve energy efficiency and reduce environmental impact. Energy engineering students will have the opportunity to work on innovative projects and contribute to developing new technologies that optimize energy use.

Sustainability

Our company is committed to environmental sustainability. We use natural refrigerants and technologies that minimize environmental impact. Science students can deepen their knowledge in sustainability and apply it in a real industrial context, contributing to solutions that respect the environment.

Professional Growth

We offer training programs and professional development to help our employees grow and reach their full potential. Economics students will gain practical skills in business management, marketing, and finance, working in a dynamic and stimulating environment.

Collaborative Work Environment

SCM Frigo promotes a corporate culture based on collaboration and innovation. We believe that success comes from teamwork and the integration of diverse skills and perspectives.

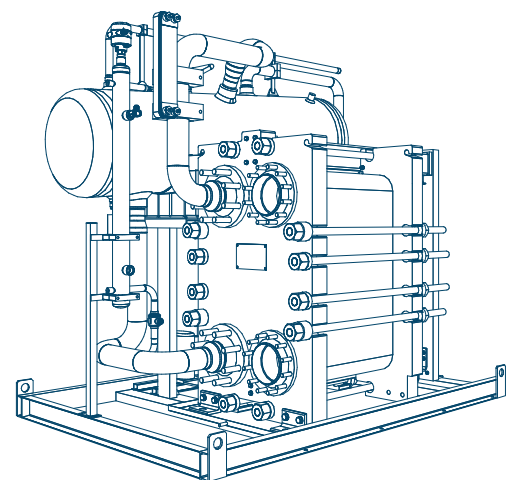

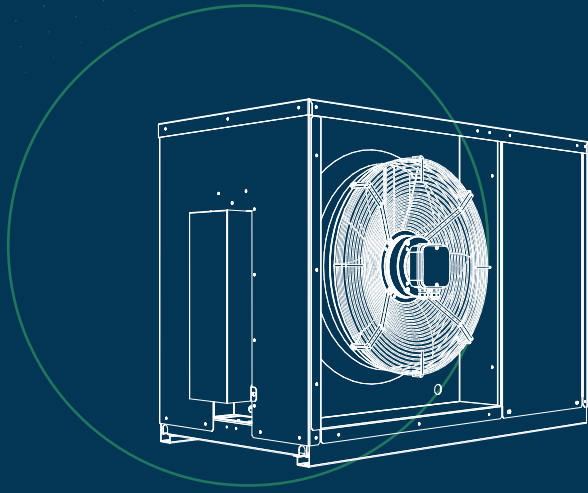

Join Us!

If you are a student of energy engineering, sciences, or economics and are passionate about innovation, sustainability, and professional growth, SCM Frigo is the right place for you. We offer internship opportunities and career paths that will allow you to put your knowledge into practice and make a difference in the refrigeration sector.

Contact us to learn more about the opportunities available and how you can contribute to our success!

Send your CV to hr@scmfrigo.com







Stay connected.

Follow our LinkedIn page to discover more stories from our team and insights into what makes SCM Frigo a leader in innovation and sustainability.



Connect with Us
on LinkedIn

 www.scmfrigo.com  +39 049 970 5000  info@scmfrigo.com

